

Regenerative Protection Module

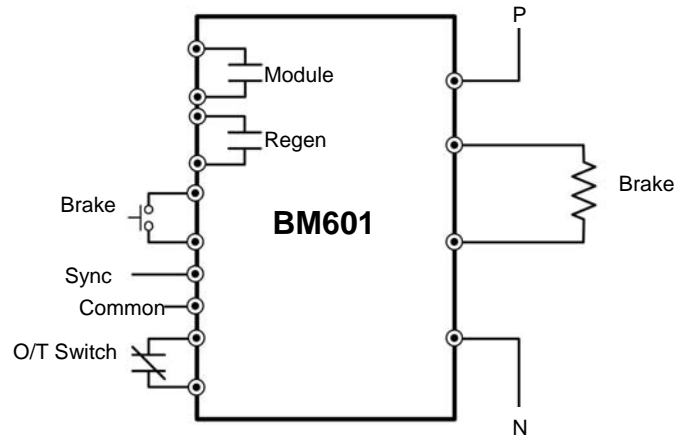
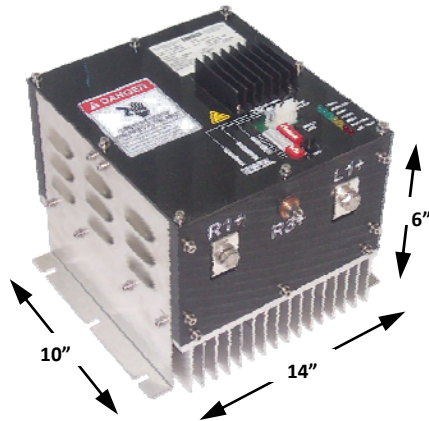

The ATS Regen Protection Module (also referred to as a dump chopper) can be used with any DC, AC, PM, Switched Reluctance, or other types of motors.

During regenerative braking, the DC bus begins to rise. If the regen voltage rises too high, damage may occur to the supply battery and other equipment tied to the DC bus. The RPM module will turn on at a predefined voltage to protect all equipment on the DC bus.

- Absorbs high voltage surges on DC voltage supplies due to regenerative braking of the propulsion system. Adjustable from 272VDC to 768VDC
- Capable of dumping up to 600A into braking resistor
- 10% duty cycle (for example, 6 seconds on, every 60 seconds)
- Contains provision for resistor over temperature protection via resistor OT sensor
- Compact, single enclosure houses all components, including internal isolated power supply
- Brake On and Brake Fault output via relay contacts
- Able to sync up to 5 modules with "first triggers all" concept (no master unit required) for a total of 3000A Braking Current
- Battery Condition Monitoring feature outputs signal indicating repeated Brake cycles, warning the operator to check the battery condition

Specifications

ATS Part Number:	A800993
Input Voltage:	200VDC to 750VDC
Braking Threshold Voltage:	Adjustable from 272V to 768V
Maximum Current:	600A (per module)
Duty Cycle:	10% (e.g. 6 seconds on, every 60 seconds)